

# **A Report on the Rehabilitation of Older Houses in a Lower Income, Inner City District**

---

**by Eric Barker  
1971**

---

**The Institute of Urban Studies**



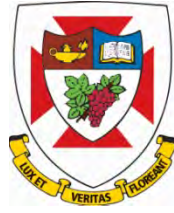

THE UNIVERSITY OF  
WINNIPEG

**FOR INFORMATION:**

*The Institute of Urban Studies*

The University of Winnipeg  
599 Portage Avenue, Winnipeg  
phone: 204.982.1140  
fax: 204.943.4695  
general email: [ius@uwinnipeg.ca](mailto:ius@uwinnipeg.ca)

*Mailing Address:*

*The Institute of Urban Studies*

The University of Winnipeg  
515 Portage Avenue  
Winnipeg, Manitoba, R3B 2E9

**A REPORT ON THE REHABILITATION OF OLDER HOUSES IN A LOWER INCOME, INNER CITY DISTRICT**

Published 1971 by the Institute of Urban Studies, University of Winnipeg  
© **THE INSTITUTE OF URBAN STUDIES**

Note: The cover page and this information page are new replacements, 2015.

The Institute of Urban Studies is an independent research arm of the University of Winnipeg. Since 1969, the IUS has been both an academic and an applied research centre, committed to examining urban development issues in a broad, non-partisan manner. The Institute examines inner city, environmental, Aboriginal and community development issues. In addition to its ongoing involvement in research, IUS brings in visiting scholars, hosts workshops, seminars and conferences, and acts in partnership with other organizations in the community to effect positive change.

V - Housing - Lower Income

HT  
169  
C32 WS85  
no. 005  
C.2

A REPORT ON THE REHABILITATION OF OLDER HOUSES  
IN A LOWER INCOME, INNER CITY DISTRICT

June 30, 1971

Eric Barker, Architect  
Institute of Urban Studies  
University of Winnipeg

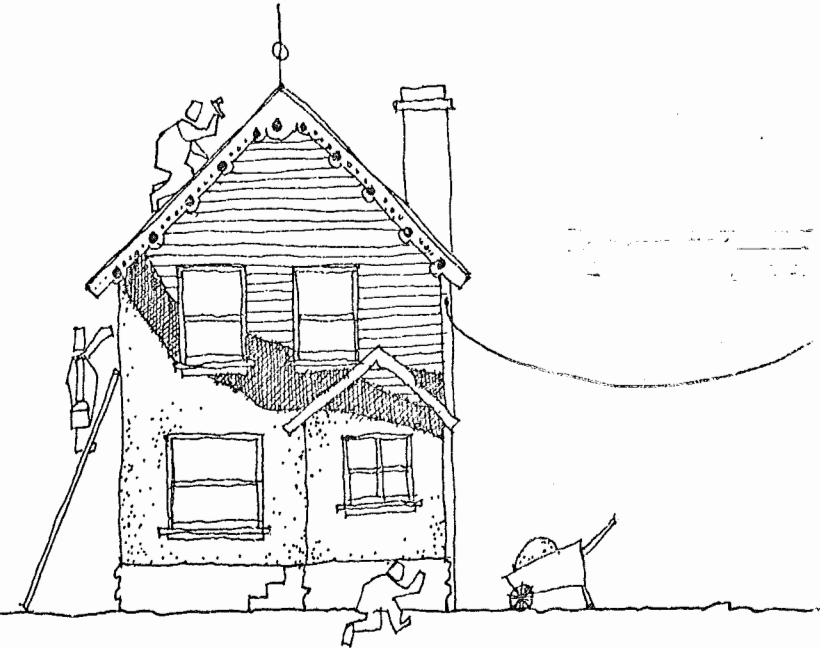

CONTENTS:

1. Context
- A. Definition
- B. Existing Situation
- C. Standards
- D. Critical Factors
- E. What Houses and How Far?
- F. Priorities: 1, 2A, 2B, and 3
- G. Limited Repairs
- H. How to go About it
- I. Non-Resident or Resident Owners
- J. Who lives in the Houses Now and Who Will Live in Them When Renovated
- K. Where Do the Occupants Go During Renovation
- L. Community Facilities
- M. Problems
- N. Rationale For Program
- O. "Death" of Poor Houses
- P. "Grass-Roots" Rehabilitation
- Q. Government Rehabilitation
- R. Local Rehabilitation
- S. Partial Repairs
- T. Absentee Landlord Program
- U. Experiments with Materials and Space
- V. Summary

CONTEXT:

This report is based on some of the work done by the Institute of Urban Studies staff with citizen groups for over a year. The focus of this work was in the area indicated on the adjoining map.

As shown, it is north of the city center but just south of the massive C.P.R. marshalling yards. Consistent with most inner city residential areas, it is one of the oldest in Winnipeg dating back 100 years. Today one finds a mixture of five residential streets, abandoned houses, railway yards, small industry and little recent growth or new construction.

It is an area which some are attracted to by its central location, good bus service and proximity of people with similar backgrounds. At the same time some are forced into the area because of the lower rents and the tolerance of landlords. It has been labelled an "urban renewal" area for 15 years, effectively preventing any private investment and leaving the people hanging.

The young people are leaving and the older want to stay because it is home. There are a great many single boarders who find accommodation since the house owner wishes to augment his income and the area is convenient to downtown. The population is dropping and 2/3 of the people are renting. It is a place in an uncertain calm waiting for an unknown storm.

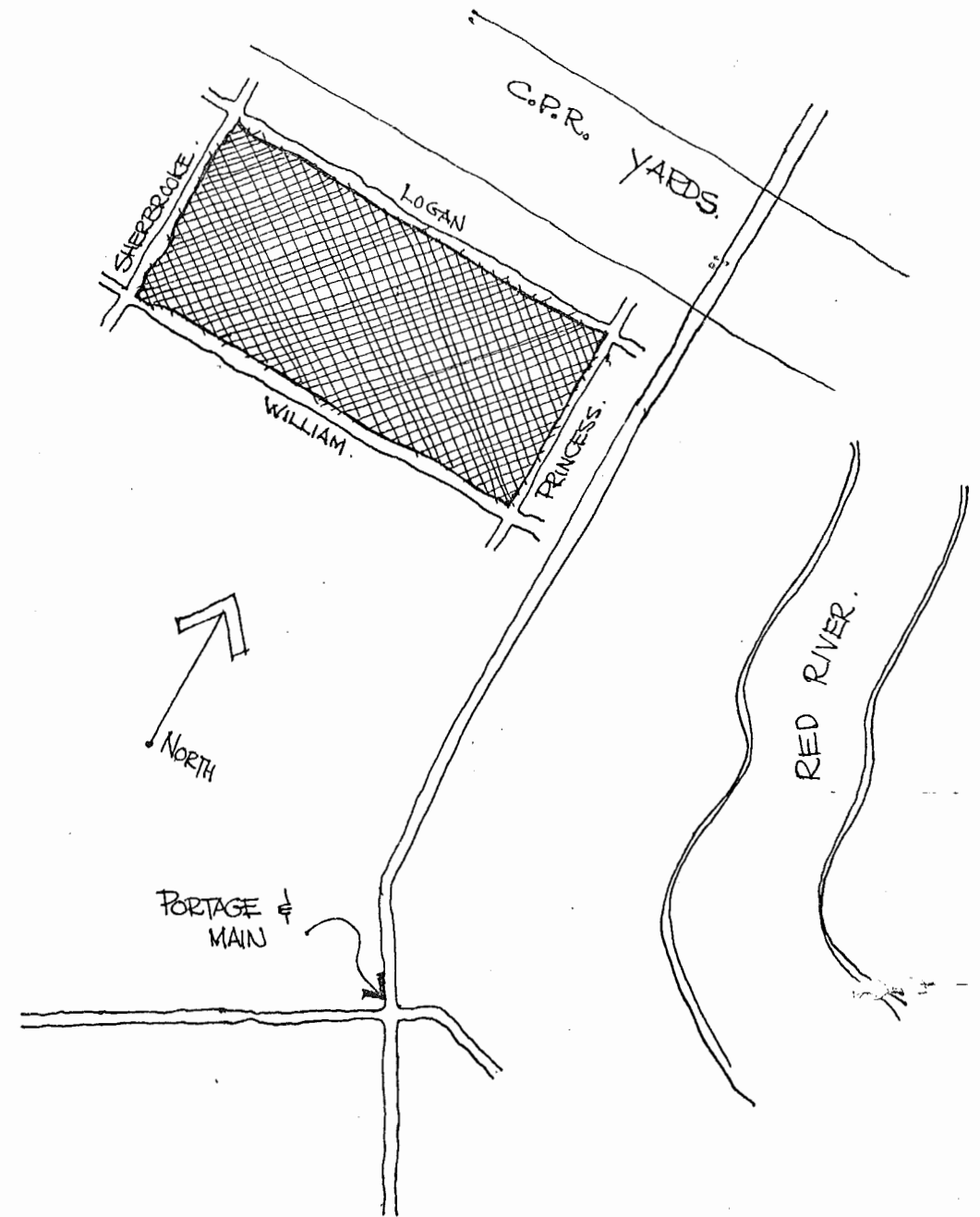

REPORT - REHABILITATION OF OLDER HOUSES IN A LOWER INCOME, INNER CITY DISTRICT

A. WHAT DOES REHABILITATION OF HOUSES MEAN?

Rehabilitation of houses means to spend time and money on a house which is sub-standard in some way, in order to upgrade it to make it more livable. Each house presents a unique situation which must be considered separately from any other house. In some cases this may mean repairing the foundation, the chimney, the floors, or putting a new heating system into the house. In other cases, very little work may need be done. But the concern should lie with upgrading those houses which do not function adequately as a living unit.



B. EXISTING SITUATION

1. The house is either 20' x 40' sitting on a 25' x 110' lot with a back-lane, or a 23' x 40' on a 33' x 79' lot with no back-lane. There are very small spaces between the houses and the property is usually fenced off. The average cost of house and land is about \$10,000.

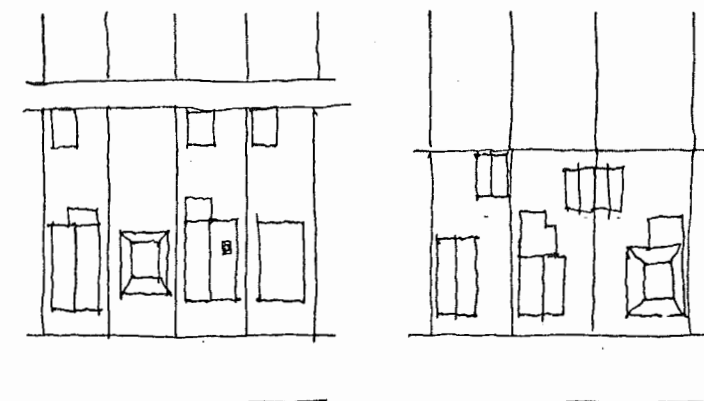

2. There are four basic types of houses:
1. 1-storey bungalow
  2. 1-storey duplex or triplex
  3. 2-storey house
  4. terrace or rowhouse



3. The houses are usually wood frame with two layers of sheathing on the outside, one on the inside with wood siding on the outside. This siding is sometimes covered with "insul" brick, real brick, or stucco. The "insul" brick tends to rott the siding.



4. The house sits on a stone foundation which falls into two categories:

A) no basement - in which case the foundation goes only two or three feet into the ground and has no footing. Because it is above the frost line and has no footing the building has likely shifted badly. These foundations were sometimes topped with a continuous wood beam. This foundation causes joist rotting around the outside of the foundation because of a lack of ventilation. The centre beam, if there is one, sits on posts which in turn sit on concrete pads.

B) with a basement - this type of foundation goes below the frost line but again has no footing, which causes shifting. The mortar used in these walls and the type of stone causes crumbling which seriously affects the structure of the building. These basements are usually low and dusty and not suitable for living quarters. The floor is usually cracked and broken. A new floor could be poured over top with sufficient reinforcing or the old broken up.

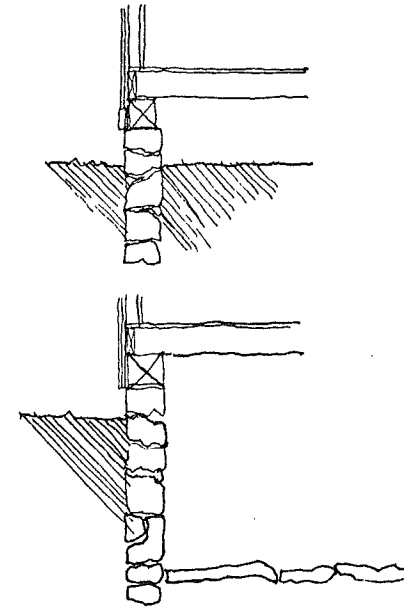

5. front porches., sometimes open, sometimes closed, seldom sitting on a foundation. These can afford effective places to sit in the summer and become part of the "street-life".

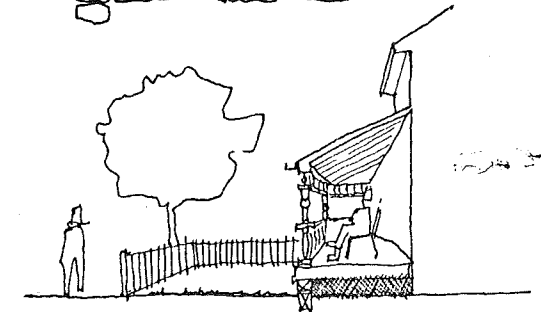

6. 1-storey rear shed, sitting basically on the ground with no foundation and left unheated for storage of wood and preserves in days gone by. If they are to be used they must be put on a foundation and heated. They can be used for kitchens or extra bedrooms.

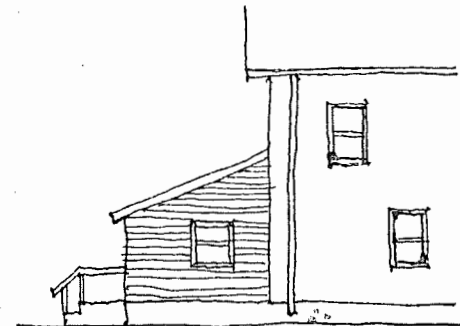

7. roofs steeply peaked to carry off water and clad with asphalt shingles. The rain water drained off the roof is often drained inside and released under the house to drain away. This can cause undermining of the foundation. The rain water leaders of these houses are usually blocked up and require maintenance.



8. houses are seldom insulated causing tremendous heat loss through the walls and roof. The cost of insulating a house is approximately \$400. The lack of insulation causes rotting of the wood in the walls and rotting of the plaster due to the passage of water vapor.

9. the interior and exterior woodwork and trim in most cases is beautiful and worth keeping.

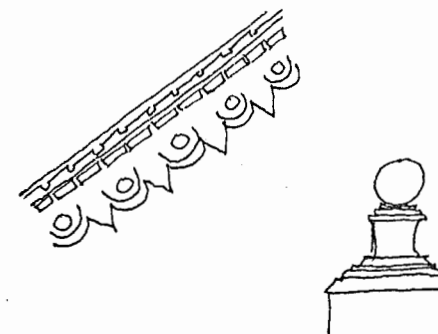



10. the inside of the house is made up of a hall, stairs, and rooms off of them. On the main floor the stairs are by the front door which makes duplexing easy. A hall then leads back to the kitchen at the rear of the house. Off of this hall several rooms are found which are used as bedrooms, living rooms, dens, and dining rooms, each separate from the other. These rooms have high ceilings and the plaster is usually in poor condition. The floor was once a hardwood floor now covered with sheet linoleum. There is no closet space in these downstairs bedrooms since they were not meant for this purpose. The doors to these rooms are either blocked off or do not close or lock properly. The windows are large giving plenty of light but are old and dried out having lost their weatherseal and in the winter, leak cold air badly usually frosting up. The kitchen has but a sink and little counter or cupboard space. The eating is done in the kitchen. The bathroom is only on the second floor. The bedrooms upstairs are small averaging 8' x 10'. The bathroom is generally small with ancient fixtures.

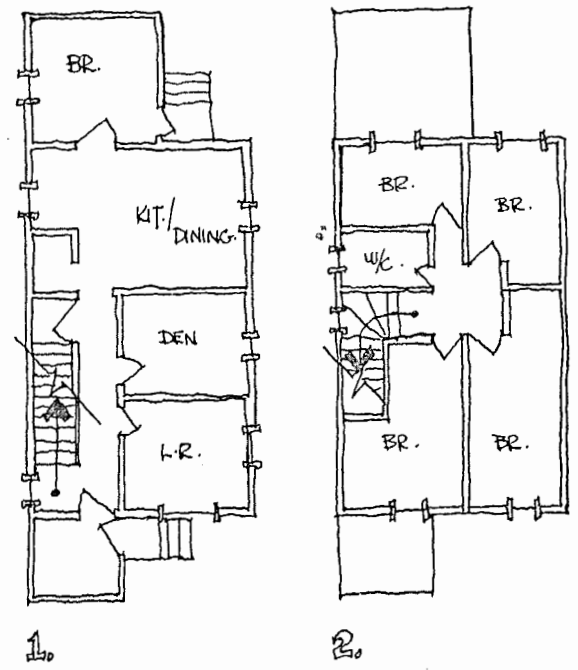

11. The heating system is generally an old coal stoker converted to forced air gas heat with no blower. The ducting is sometimes run exposed through the rooms causing a great deal of heat loss on the way to the room. The positioning of the hot air supply ducts and cold air return (if there is one) is bad.

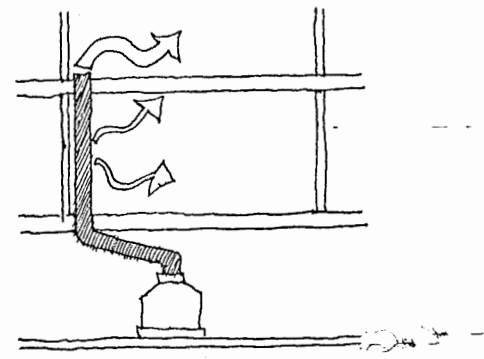

12. The plumbing is old and if repaired would have to be updated.

13. The wiring is sometimes exposed. There are too few wall outlets. and the capacity of the wiring does not handle the large number of electrical appliances available today.

(Note: with regards to plumbing and electrical work, the owner has often done his own repairs and alterations which, if the house was repaired under a permit, would have to be updated to present standards.

### C. STANDARDS

If we were involved in repair work that required a permit from Metro, we would have to comply with their standards. This may cause problems, as mentioned earlier, in that an old house will have to be brought up to today's standards.

These standards apply to:

1. structural aspects of building such as
  - A. size and span of floor joists and beams
  - B. size of posts
  - C. size and number of studs in a bearing wall
2. plumbing and heating
  - A. type and sizing of piping and joints
  - B. size of furnace related to size of house
  - C. method of distributing heat
3. electrical
  - A. must not be exposed
  - B. switches and capacity of wires
  - C. service panel and fuse box
  - D. number of outlets in any room.

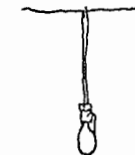

## 4. occupancy

A. no extra suite is allowed in the basement or attic giving living space on three levels.

## 5. if duplexed

- A. clad basement ceiling with 5/8" fireguard.
- B. separate two units with 1 1/2 hour fire separation, this may mean cladding main floor ceiling with fire-guard.
- C. separate front stairway from the rest of the house.
- D. provide a secondary exit from the second floor suite, directly outside.

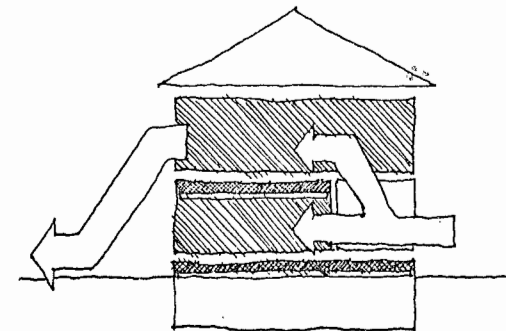
D. CRITICAL FACTORS AFFECTING FEASIBILITY OF REPAIRS

There are certain basic factors which determine whether a house is worth repairing or past the point of repair.

1. The foundation - if it is sagging downward or inward it would need extensive repairs. With no basement, the lack of ventilation will have caused joist rotting. If the house appears to be tilting, the foundation is likely bad.

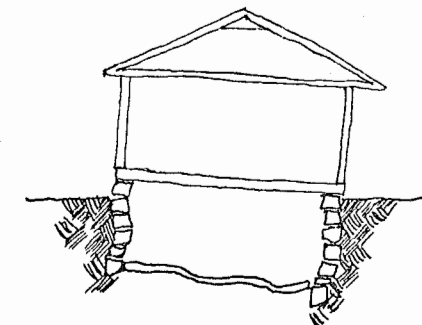

2. the main structure - if the floor joists, walls or roof appear to be rotting or sagging, the house has not long to live and no amount of work can put it in good condition.

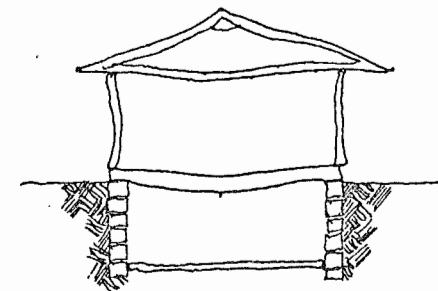

3. the heating and plumbing system - these should be checked by a qualified person as to their condition and efficiency. The winter heating bill can give you an idea of the effectiveness of the system and the insulating quality of the house.

4. the electrical system - the capacity and condition of the system should be checked by a qualified person.

5. the condition of the roof, the exterior wall and windows.

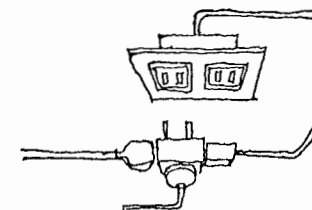
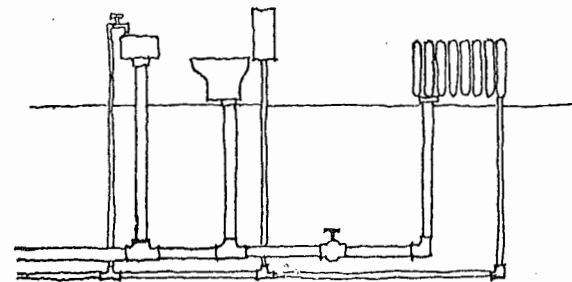

#### E. WHAT HOUSES TO REPAIR AND TO WHAT EXTENT

At this point, when considering the question of what houses to repair they must be in some state of disrepair. A "good deal" in a house is not the goal, but a house which is, in fact, in poor condition but not literally falling down - a house, which, when repaired will stand for another 25 years.

If the cost of repairs to the basic factors mentioned earlier approach the cost of the house, itself, the cost of building a new house or an amount which might be used to repair two or three other houses, it would be a poor investment. If too many of these basic factors are faulty, the house is past its prime and should be encouraged to die.

## F. PRIORITIES

The concept for the rehabilitation of older houses should be to repair as many houses in the poorest condition to a point where they are functioning adequately as a living unit. What this means is rather than completely renovating one house, you repair the critical problems in several houses. In this way, more people will benefit from the program. The less critical problems can be attacked at a later date. This leads to the establishing of a set of priorities and cost ceilings.

### PRIORITY #1

This is the first, most important priority relating to those critical problems affecting the safety and health of the occupants. The factors included in this priority are those mentioned earlier as being the ones which, if most or all are faulty, may place the house past the point of reasonable repair. The cost ceiling on these repairs should not allow all of these factors to be repaired. If all are faulty and require repairs, the house is ready to die.

1. repair roof if it leaks, insulate ceiling with Zonolite.  
Cost: \$800
  
2. repair windows if broken or leaking air - perhaps replace outside sash with aluminum-storm and screen.  
Cost: \$350

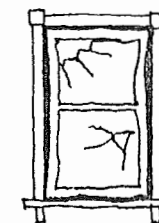

3. repair holes in exterior wall and perhaps blow insulation into wall if wall is cold.  
Cost: \$400
4. repair floor joists, ceiling joists if broken, rotting or if there are too few of them to support load.  
Cost: \$250
5. repair crumbling foundation, underpin or perhaps jack house up and put a new centre beam in..  
Cost: \$1,500
6. repair or replace heating system/chimney repair  
Cost: \$1,350
7. repair or replace plumbing system or fixtures  
Cost: \$1,000
8. repair sagging structural walls  
Cost: \$250
9. rewire house to upgrade capacity  
Cost: \$350

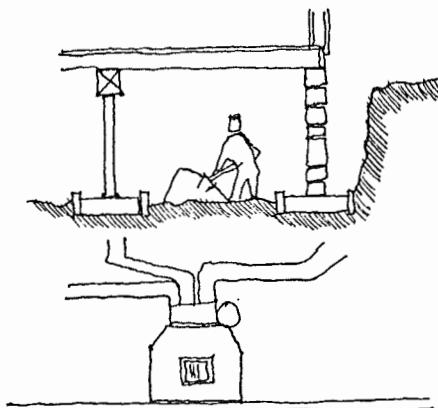
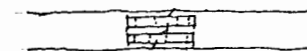
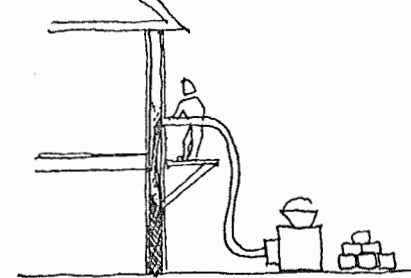

10. patching interior walls to cover repair work.  
Cost: \$200

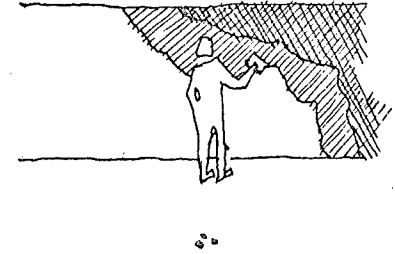

TOTAL COST: if all factors required - \$6,450

Cost ceiling on first priority repairs-\$3,500

With this cost ceiling, certain repairs could be done but not all. If the cost of the necessary work required on a house was above this figure it would be considered a poor risk. The figures shown above are rough estimates and would have to be tested not only as to their validity, but also the validity of a standard price ceiling. Each house is a special case and may have other redeeming factors which make steadfast rules difficult to apply.

PRIORITY #2 A

These are not problems affecting the functioning of the unit, but are those "little things" which frame the everyday life of the occupants. To the people living in the house, those factors are often very important since they must face and cope with them everyday. For this reason, the feasibility of these repairs should be weighed against those of the first priority. This work could be quickly done by the occupant with help and advise from others.

- A. repair or replace interior fixtures or finishes  
1. replace worn out floor tile  
Cost: \$100

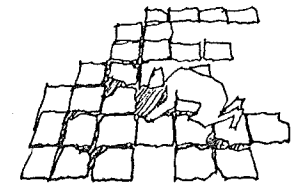

2. sand and refinish wood floors  
Cost: \$100

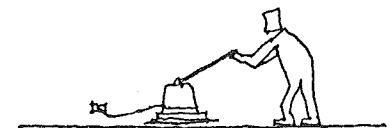

3. repair holes in inner walls, patch plaster, baseboards  
Cost: \$200

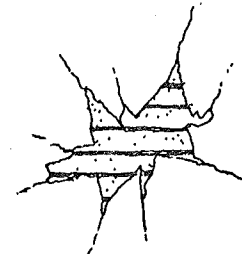

4. replace light fixtures  
Cost: \$25

5. wash and paint walls  
Cost: \$300

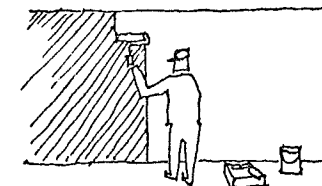

6. add closets, cupboards, and counterspace  
Cost: \$200

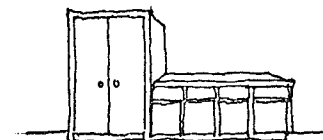

7. repair or replace old doors  
Cost: \$100

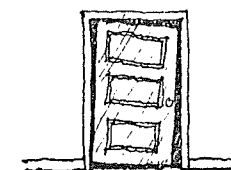

TOTAL estimated cost: \$1200

This figure represents the total estimated cost of repairs to the above factors on the open market. Two points should be remembered.

1. these factors will not all be problems in every case
2. much of this work could be done by the occupant and "repair team" together to save cost.

these- With 7 points in mind we could lower the average cost of this work in a house to \$600.



PRIORITY 2B:

The reorganization of the internal layout of the house to give more space or add living units. The emphasis being to give everyone a private, self-contained unit. This possibility should be considered when looking at the first two priorities in that the ground work could be laid for this work in the future or in fact done at the same time at less cost than if it was done at a later date.

1. remove or change walls to provide bigger more useful rooms.  
Cost: \$1000 to \$2000

2. make an old single family house into a duplex with a suite on the main and second floor.  
Cost: \$2000 to \$3000

3. reorganize the main floor or second floor to accommodate single boarders.  
Cost: \$2000 to \$3000

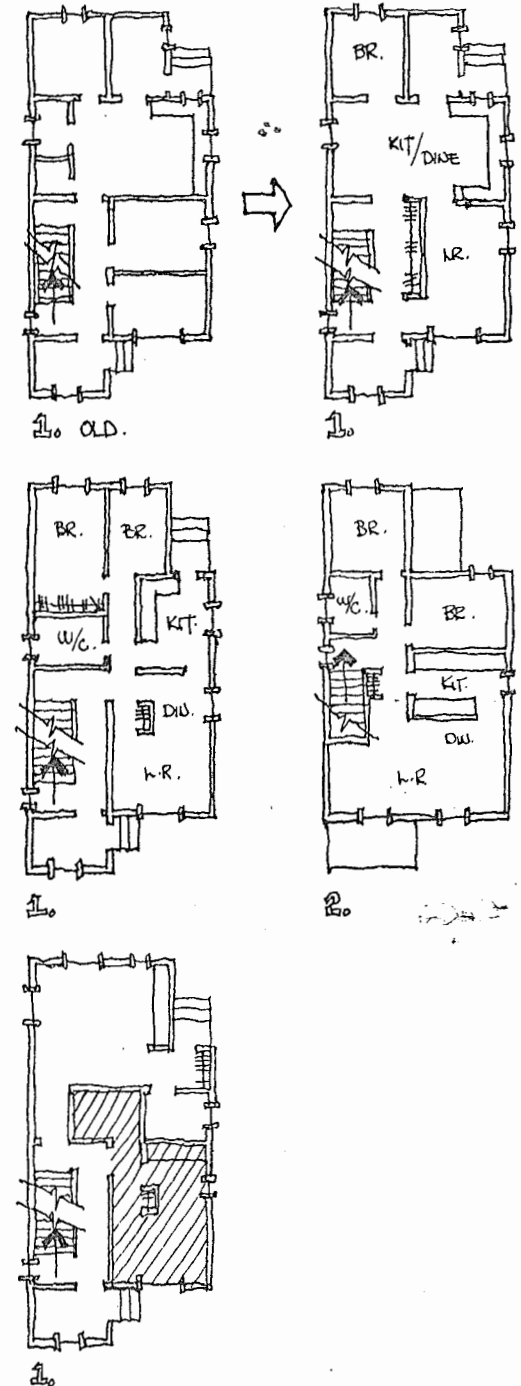

4. experiment with maximizing space by stacking beds, living areas or storage units.

Cost unknown.

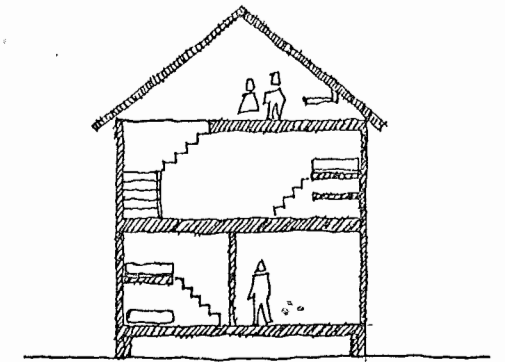

The cost of renovation work in this priority ranges between \$1000 and \$3000. These figures are rough estimates of the range of costs and are difficult to pinpoint without an actual costing of a specific situation. There is also PRIORITY #3 cost overlapping between priorities 1, 2A, and 2B.

This priority concerns the external appearance of the house and yard and is least important as it affects the daily life of the occupants. to a lesser degree.

1. paint house, fence, and garage  
Cost: \$400.

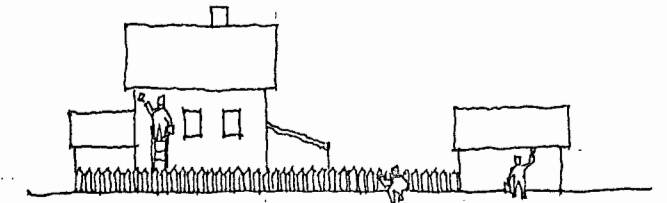

2. remove old siding and replace with new siding or stucco  
Cost: \$500.



3. install <sup>new</sup> concrete steps or repair old steps  
repair cost: \$50.  
new cost: \$400

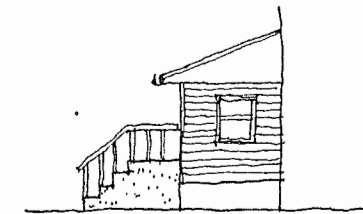

4. repair fence, grass, sidewalks  
Cost: \$200

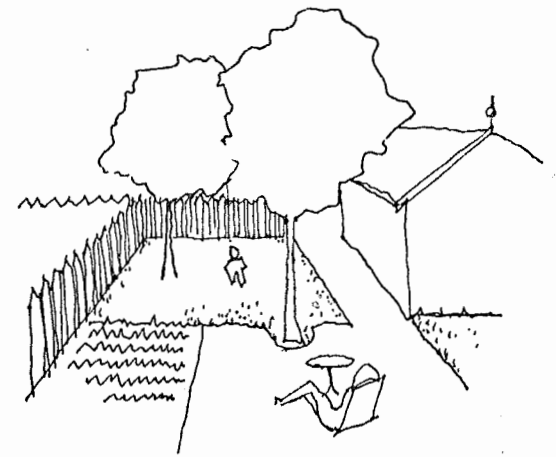

5. add patio and trees  
Cost: \$150

6. parge basement wall  
Cost: \$75

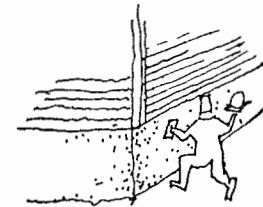

7. repair front porch  
Cost: \$150

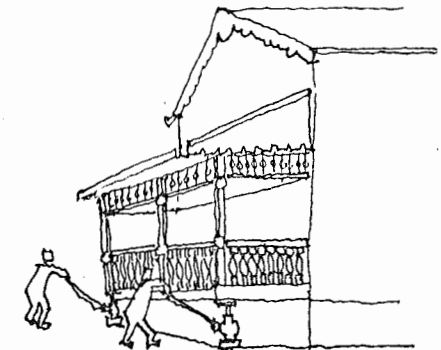

8. move or add garage  
Cost: \$600

9. repair eave troughs  
Cost: \$150

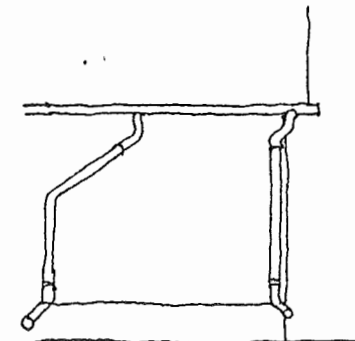

Total estimated cost of repairs to above factors \$1900

This figure could be lowered to approximately \$1000 since all this work would seldom have to be done and much of it could be handled with local help. The work could also be phased over a longer period of time as money and help were available.

In summary, the rehabilitation of an older house should be approached in three phases or priorities. These priorities are:

1. Repairs to those critical problems affecting the functioning of the house. This should be the first goal of any program. The purpose of the cost ceiling here is to prevent money being spent on a house which is past the point of repair.

Cost: \$3,500

2. Repairs and alterations to the interior finishes and layout of the house.

A. finishes  
Cost: \$600

B. layout \$1000 to \$3000

3. Repairs to the exterior of the house and yard  
Cost: \$1,000

The amount spent on one house would then amount to \$6,000 over a period of time. By repairing a number of houses at the same time and perhaps putting more dollars into interior work, layout alterations could be included in this \$6,000 figure. The \$1,000 on exterior repairs could be lowered and re-assigned to the interior work to allow more layout alteration.

#### G. LIMITED REPAIRS

In many cases, after considering the condition of the house and the priorities, we will find houses that are either too poor or too good to be worth repairing in a larger sense. In these houses the work done may be on a small scale to solve small problems.

This should be an important part of any comprehensive rehabilitation program. It is often the broken windows, the rubbing door, the cold room and a lack of counter or storage space that bothers people. These are the problems he has to cope with every day but because of a lack of money, skill or initiative, must live with. These repairs can be done quickly and easily giving the occupant tangible proof of how rehabilitation can work.

Limited repairs can be carried out in any house, even one which is in very poor condition. As they cost little in terms of time and money but make the occupants life a little easier.

The work may be done by the occupant if shown how or by a repair team circulating through the area. This team could assess problems, offer advice, procure materials and even do the work itself. The team could be made up of local handymen, contractors, plumbers, electricians, and architects. This limited repair work could even move into what is mentioned earlier as priority 2A. This program could be carried on while the more extensive work is being done in other houses.

I cannot emphasize enough, the value of such a program. The grandiose ideas and projects solve some problems but in the early stages it is often the little things that count.

#### H. HOW TO GO ABOUT IT

A survey of houses would have to be made to find out which ones are in poor condition. The survey could be carried out by the "repair team" mentioned earlier, who, while doing limited repairs could assess the houses as to more extensive work required. Estimates on the repair costs would be prepared by the "repair team". The estimated costs of repairs of the first priority would be tested against the proposed cost ceiling to see if the cost ceiling principle was workable and if the repair work was worthwhile.

The cost of repairs to ten houses at the same time rather than one should be utilized to maximize money, time and materials. These ten houses would be repaired to the first priority rather than spending the same amount of money on repairing five houses completely. In that way, better housing has been provided for more people.

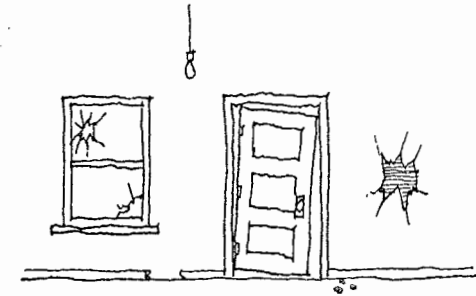

PEOPLE COULD DO WORK

If these houses were in poor condition, there are likely repairs required under the second and third priority. Once the houses were repaired to the first priority, we could arrange with the people that move in that material and technical help will be supplied and they will in turn, supply the labor towards fixing up the rest of the house. This labor by the individual could be his downpayment on the house and gives him a stake in the house. This would attract people who want to stay in the area and make use of building skills which they have.

I. NON-RESIDENT OR RESIDENT OWNER:

Which houses do we concern ourselves with - those owned by a resident or a non-resident? I think, for the most part, we find the problems in those houses owned by a non-resident landlord. This is sometimes the fault of the tenant, sometimes not. The resident landlord naturally takes care of his house since he lives there and is his source of income.

J. WHO LIVES IN THESE HOUSES?

## A. Non-resident-owner

1. large families unable to find accommodation elsewhere because of the size of their family.
2. a number of boarders

## B. Resident owner

1. old couples whose family has gone and finds house too large and too much trouble.
2. the family of the owner on the main floor, and the second floor rented to a family or boarders.

WHO WILL LIVE IN THE RENOVATED HOUSES?

Who needs housing?

1. large families
2. senior citizens - singles and couples
3. young couples with one child
4. bachelors and single people with a limited income

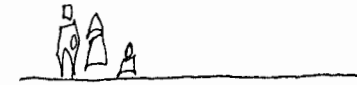

By renovating houses we can supply housing for:

1. large families
2. young couples with one child
3. single boarders with limited income



We cannot provide housing for older people because of the problem of stairs and up-keep required.

K. WHERE DO THE OCCUPANTS GO DURING THE RENOVATION?

There are people living in these houses that are being repaired. What happens to them?

For the majority of the repair or renovation work involved, the occupants could likely remain in the house if they are willing to accept some inconvenience. If the situation becomes unworkable they may:

1. send the children to a relative's house
2. move into a vacant suite in the area paid for by the government
3. live with relatives

Another alternative is to phase the renovation of several houses so that work begins on vacant houses or on ones which the family has moved out of. These few houses could be repaired and people from the other houses shifted into the newly repaired one.

An added factor might be to try and develop initially an alternative type of rented housing for the older couples living in larger houses. When the older couples moved out, their old houses could be held and used as temporary or permanent accomodation for persons displaced by the renovation process.

#### L. PROVIDE SPACE FOR COMMUNITY FACILITIES

Rehabilitation can provide space for offices, restaurants, and club rooms. This process can begin to strengthen the character of the area. I think it is most important to begin thinking of how we can strengthen those characteristics which make this older area of the city unique. If the character of the area is strong, it can better accept new buildings. The houses could be turned into offices or stores where they stand or could be moved to a new site where they might begin to generate an "old town" shopping street. By moving the houses, the life span of the house has been strengthened (old foundations are poor) and the usable interior space has been increased.





M. BUT WHAT ARE THE PROBLEMS?

Isn't it a poor policy to put money and time into houses that are an average of 50 years old. Even when we put this effort into these houses we have not really increased the living space of the district but only upgraded what we now have. Renovating houses, is a slow and costly process. It takes time to assess the condition of the house and even then, there are many "unknowns" which we find as the job progresses and are very expensive. The major cost in building is labor and the labor cost is higher in renovation work since the workmen must always try to fit the new to an old situation. By nature of the type of work, the houses are usually on separate lots which means there is a great deal of duplication at each job site. Each house requires its own new materials so you cannot really buy in bulk. It is also very difficult to find reliable contractors to do this sort of work, and the job requires a great deal of supervision time. Why bother with rehabilitation at all?

N. REHABILITATION OF OLDER HOUSES IS A DIFFICULT BUT NECESSARY PART OF COMPREHENSIVE RENEWAL PROGRAMS

In some cases it is a poor investment to put money into a house which is falling down, but most of the houses are not in this condition. These houses were well built and it has been said by people who have done this work that with the right work in the right places, these houses can stand and function for another 25 to 30 years. Therefore, by putting money into these homes, we can significantly increase their life span.

It is true that this program does not increase the available living space of the area and it is, by comparison to building new homes, a much slower and costly process. But I think, the first step in the revitalization of an older district is not to build new housing for people outside the district but to stabilize and improve the situation for the people here now. Through this program of rehabilitation we not only improve the quality of life for people with little money or choice but we will give people of the area confidence that something good is happening. This will encourage others to repair their houses

which they were afraid to do before because they didn't know what would happen here. Surely if we live in a district where most of the houses are old we must try and keep what good houses we have, encourage the death of those that are too old and also build new houses for those people who can't initially live in these houses. We cannot just let all of these houses die off; it is a costly waste of time, repair money, and is unfair to those that live in them.

Another justification for rehabilitation is the fact that by doing this work we are saving a house from short-term demolition. By spending a limited amount of cash on this house we have provided adequate accomodation at a reasonable price - accomodation that would have had to be torn down and replaced with a new, more expensive unit. This makes sense from the point of view that we have houses that are predominantly over 60 years old and people living in them who cannot afford to pay a high price for their accomodation. Thus, it is a subtle form of low-income housing.

#### 0. ENCOURAGE THE "DEATH" OF POOR HOUSES

An important apart of any rehabilitation process is to encourage the early death of those houses past the point of repair. In order to do this we must:

1. provide a source of emergency housing which can be used as a "hammer" in dealing with landlords who refuse to repair. This housing would give the family an alternative they did not have before. Once in the emergency housing units try to find accomodation in existing houses or in a new development within the area.
2. establish a set of meaningful "adequate" standards rather than simply "borderline" health standards.
3. form a local "grievance" committee to harass and put pressure on landlords or owner.

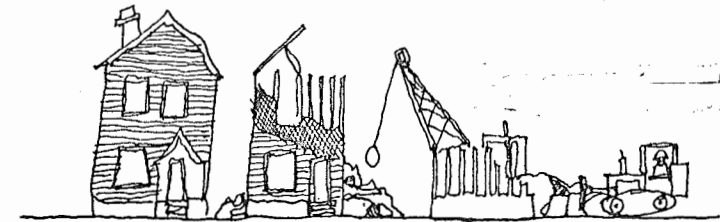

The wrecking of these houses could be done during the winter to provide jobs for the local unemployed. The used material could be kept in a warehouse for use in the rehabilitation of other houses. The problem with using unskilled labor on the sort of job is that they ruin most everything they take apart. But, perhaps, with proper supervision, this problem could be minimized.

P. THE COMMUNITY MUST PLAY A ROLE

Within the community, as mentioned earlier, there is a great deal of expertise in the building trades. Some of the residents make a living repairing homes and either renting or selling them. Many of the residents are capable of doing repairs but do not because:

- house is not worth the trouble
- cost of home improvement loans is high
- work hard during the day on construction and do not enjoy a bus man's holiday.
- don't know what is going to happen in the area.
- are afraid of increased taxes.

These concerns highlight some of the problems and but also tell us that there is a certain mechanism within the community waiting to be utilized. These people have access to reliable skills at reasonable prices. - "I have a brother who has a friend whose uncle is a plumber". They also save used material and barter with each other for materials when repairing a house. Any rehabilitation program should make use of this established renovation system. A description of such a process in which a local handyman and landlord repaired a house slated for demolition follows.

A study in "grassroots" rehabilitation

Many people who live in this district buy and repair houses themselves charging reasonable rents thereby conducting rehabilitation in the private sector because of the profit motive. This is a documentation of an example of this type of work done on a house on Elgin Avenue.

Type of House:

cost - \$2100 land and building  
 lot - 30' x 112'  
 building - 20' x 30'

-no basement (furnace pit only)

-main floor - Living room/dining room/kitchen/small washroom

-second floor - four bedrooms/washroom

-wood frame building

-foundation - stone 2' - 0' deep into ground  
 -continuous wood beam on top of stone foundation

-new shingles on roof, roof rafters around logs.

-4" wood board siding.

AGE - 75-100 years.

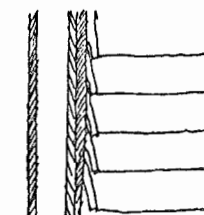
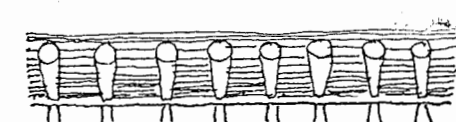
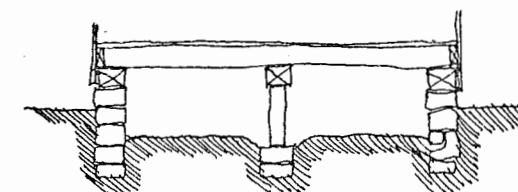
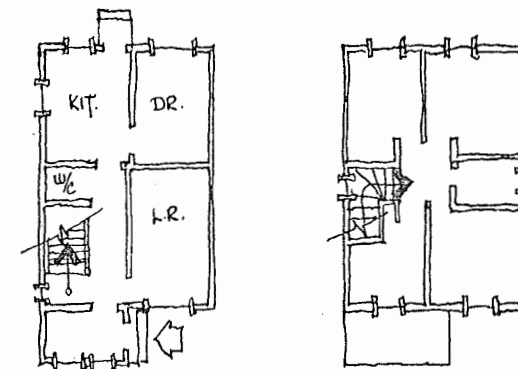

CONDITION OF HOUSE WHEN BOUGHT

-originally bought to tear down

-sewer broken under foundation in three places, terrible smell filled house.

-building sagging towards the rear of the lot

-pit for furnace half filled with water

-furnace O.K., hot water heater good, forced air heat ducts exposed, two rooms upstairs not heated - had a new chimney

-joists O.K., lumber roughsawn

-front porch sagging badly

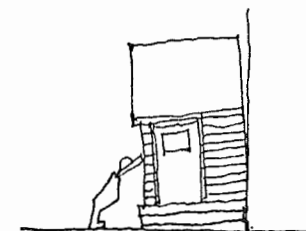
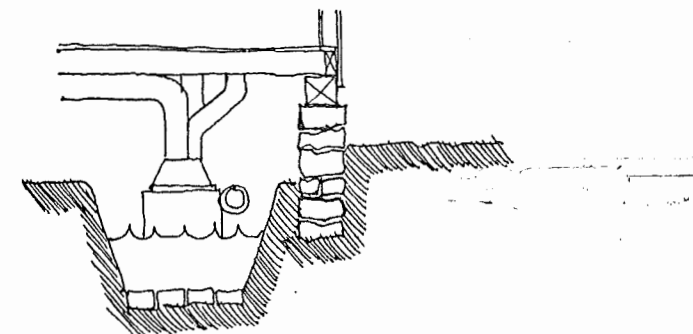
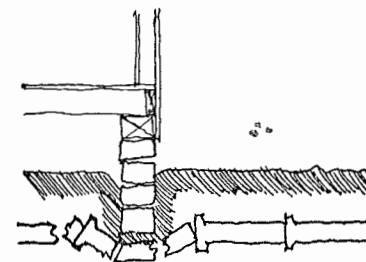

-main beam in basement on concrete pads, O.K., structure basically in good shape.

-all windows warped, leaking air, bad seal and fit.

-inside plaster hanging off walls in all but two rooms and bathroom.

-floor rolling and uneven

-kitchen had only a sink, no cupboards or counter.

-one toilet with box broken

-paint peeling outside on side and rear wall, front wall already covered in asphalt shingles

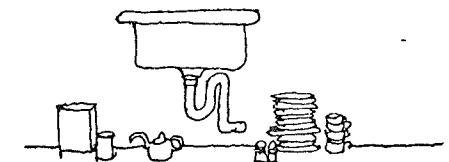
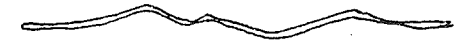
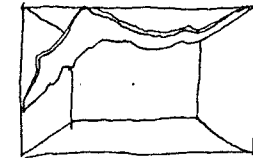
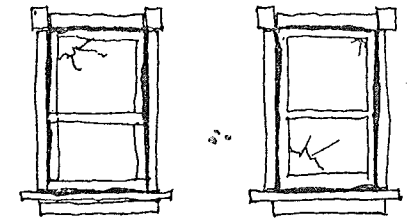

-new wiring throughout, no direct service to refrigerator or stove.

-interior doors in bad shape.

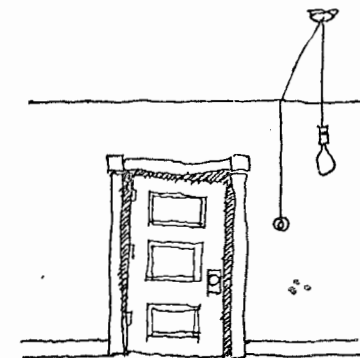

### WORK DONE ON HOUSE

-basement partially dug out, mud walls shored with old bricks, stairs built, concrete slab poured with drain, furnace and water heater put in basement, two windows built into foundation for ventilation.

-sewer line torn up and replaced, water line O.K.

-duct work extended for two new rooms and registers replaced in all rooms.

-foundation shored up where sagging with used concrete blocks.

-new parge coat on exterior of foundation wall.

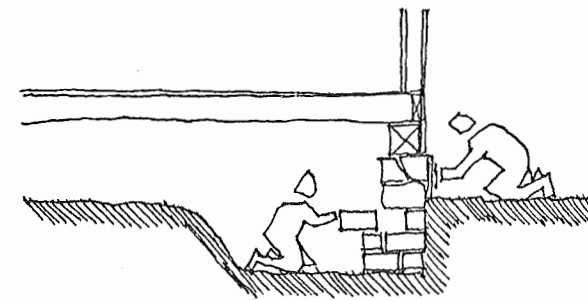
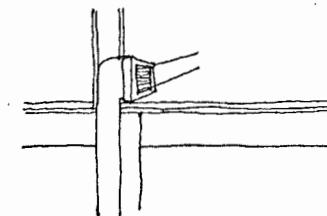
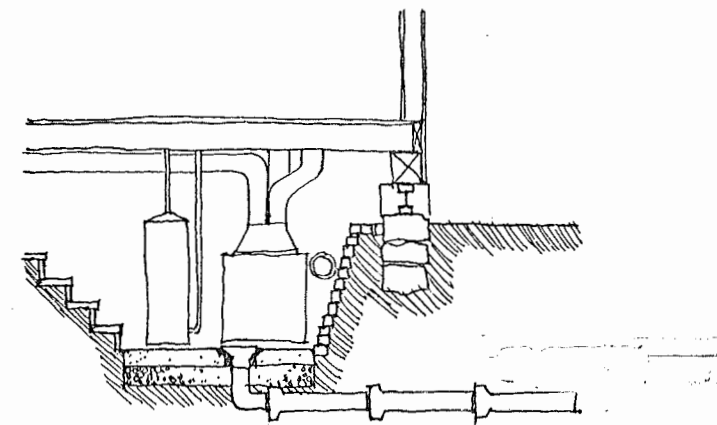

-front porch raised and levelled, glazing in porch replaced with old glazing from used door.



-all windows planed and fitted (inner sash) aluminum, storm and screen put on all windows except front picture window.

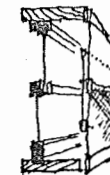

-old window in kitchen removed and smaller window built higher up with aluminum siding sash and screen.

-floors in house levelled by placing new sheets of 1/2" plywood right over old floor and shimmed level, new floor tile on all floors on main and second floor.



-new plaster board placed right over old plaster to save time and trouble of removing old plaster. Duct concealed in walls at the same time.

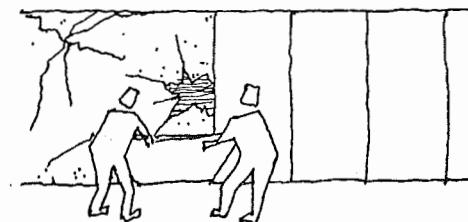

-new baseboards in all rooms.



-new counter and cupboards with stainless steel sink built in kitchen

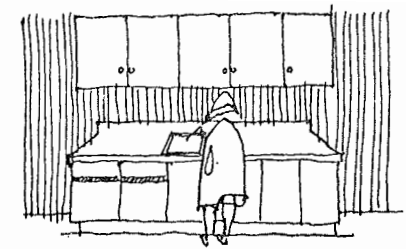

-used toilet to replace the old



-used doors used to replace ruined doors.

-paint on outside of house sanded off and two coats of paint applied.

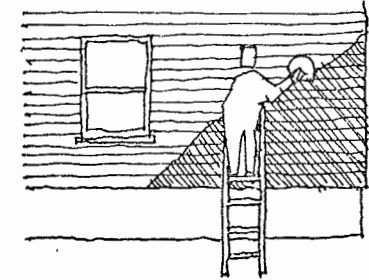

-light fixtures changed

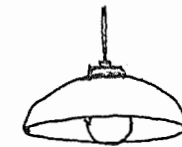

-interior totally repainted

All of this work was done by a man and his family with the help or used materials of friends in certain trades. The work took a full summer or five months. The cost of the renovation was about \$2000 in total not including the man's own labor which averaged about six hours a day (after work and on his holiday). Although some of the materials such as gyproc, plywood, floor tile and paint were new, a great deal of the material was used and help was provided by friends. Not only was the price of new and used materials cheap but the labor cost was very reasonable since the gentlemen knew these people and was able to deal or ask for favors having helped them before. This in an example of a system of construction truly

integral with the fabric of neighbourhood relationships.

Then the total price of the job was	\$4100
house and land	\$2100
materials and	
labor	\$2000

If we were to consider his labor cost at say \$3.50/hour for 6 hours a day;

7 days a week for 5 months we have a cost of:     \$2800

A real estate estimator suggested the house would be worth in neighbourhood of \$12,000

So even if we consider the labor at	\$2800
	\$4100
	<hr/>
Total Cost:	\$6900
	<hr/>

We have a profit of approximately \$5000.

What have we learned from a study of this house? I think we have seen how a local man with experience in this field can, with a limited amount of money, used materials, and help from his friends, transform a 75-year old house originally slated for demolition into a livable family house. This is a natural form of rehabilitation within a neighbourhood whereby a house falls into disrepair, is not worth very much, allowing a man with not a great deal of money to buy it and repair partly for the joy of it and partly for the investment. There are other people within the district who have done this work and are doing it now.

#### HOW CAN "GRASSROOTS" REHABILITATION BE ENCOURAGED?

In studying the example of the aforementioned house we found a man with some general building skills and a little money save a house from the brink of destruction. This sort of work depends on



three factors:

1. a house in poor condition selling for a low price.
2. a man having access to cheaper building skills and used material.
3. able to do most of the work himself.



This sort of work could be encouraged by"

1. utilizing the "sweat" equity principle of mortgaging whereby you finance the cost of the house 100%, (see explanation below).
2. offering lower interest money to local landlords to repair under a general specification with the opportunity to re-sell back to the government or private sector.
3. establish a local tradesmen list to give local landlords an idea of the availability of labor.
4. establish a local centre for cheaper new or used materials.
5. government buys poor houses, lowers price and offers to local community as a "handyman" special.
6. establish a local rehabilitation company.

NOTE: Explanation of the "sweat" equity principle of financing

Very simply, the principle is that if a person is buying a house requiring some repair and is willing and able to do the repair work himself, he can receive a conventional loan to cover his downpayment and repair expenses. This technique could be effectively utilized in an area where many of the people have building skills.

The process is as follows:

- |   |          |
|---|----------|
| A. Assume the asking price for a house is                         | \$11,500 |
| B. The cost of repairs on the open market                         | \$ 3,500 |
| C. If the new owner did the work, the repairs would only cost     | \$ 1,500 |
| D. Add the asking price and the cost of repairs done by the owner |          |

\$11,500
+\$ 1,500
<hr style="width: 50%; margin: 0 auto;"/>
\$13,000
<hr style="width: 50%; margin: 0 auto;"/>

E. This cost, \$13,000 is 95% of the total cost since the owner must offer 5% equity.

So  $\$13,000 = 95\%(x)$   
 $\$13,684 = (x)$

Thus you ask for a mortgage of \$13,000 which, the owner says, covers 95% of his cost as the asking price is \$11,500 and the repairs will cost (\$13,684 - 11,500) \$2,184.

Thus you have covered the cost of the house and the repair work required to put it in good shape.

Q. CAN A GOVERNMENT EFFECTIVELY CARRY OUT THE TOTAL REHABILITATION OF  
A DWELLING

In the spring of 1970, the city of Winnipeg, sanctioned an experiment carried out by a graduate architect. The experiment was to take two houses in an older section of town, which the city presently owned (because of default on back taxes) and completely repair them. The architect did the drawings for the job himself and utilized the services of a local architect's office for specifications work and general advice (structural, plumbing, and heating, etc.). The jobs were then tendered through the local builder's exchange and work started. One house was vacant and one occupied. The plan of action was to repair the vacant house first, move the family from the one house into the newly repaired one and repair the other house. Thus, this was a job done completely by outsiders with no connection to the local community.

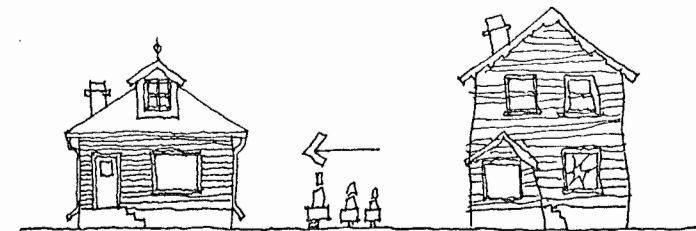

The vacant house was in poor condition having been unoccupied for several years. The concept was to reorganize the interior layout and do a complete renovation from top to bottom. In speaking with the architect he found several problems with the job.

1. difficult to know the extent of work required, must tear apart walls and ceiling to discover future potential problems.
2. once started, how far do you go - do you patch that wall or cover with new drywall etc.
3. dealing with a reliable contractor in terms of price, time, terms of contract.
4. unknowns involved
5. slow
6. relocation of people already in house
7. if renovating several houses in an area, blocks apart, duplication at each site inefficient.

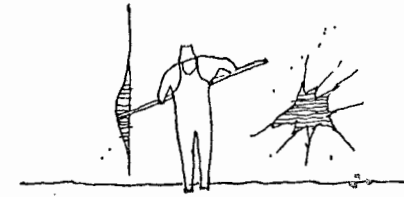

In looking back in retrospect, he had several suggestions:

1. use of a "cost-plus" contract. With this sort of contract, the contractor computed his total cost in labor and materials after the job is completed and adds on his profit margin as net cost. Thus with this type of job and its inherent "unknowns" the contractor bills you only for the work he has done. If he were to bid on a stipulated sum contract basis, he would have to build these "unknowns" into his price making it much higher so he would not be caught with these extra costs. The disadvantage of the cost-plus contract is that you don't know what the final price will be and your supervision time on the job is very high.
2. phase renovation so people can be moved from old units to newly repaired units with little inconvenience.
3. possible utilization of a "turn-key" system whereby government would limit their involvement to a call for houses to be repaired and provision of a general specification.

The following is a description of the house which was repaired:

72 Barber - Point Douglas Area

-lot size 33' x 110'

- house size 21' x 40' - 1100 sq. ft.
- partial basement, 2-storeys high
- total time spent on job from conception - 11 months.
- construction time - 2 1/2 months
- supervision every other day.
- stipulated sum contract

WORK DONE:

- new wiring
- new plumbing and fixtures
- new roof
- new forced-air heating system
- re-point foundation (patch cracks)
- new stairs to second floor
- new floor tile
- remove old "insul"brick siding, refinish and paint.
- remove some interior partitions and replace with new partitions in a new location.
- patch some interior plaster.

COSTS:

land and building	\$2000
demolition and cleaning	\$ 800
carpentry and millwork	\$2903
floor tile	\$ 139
drywall	\$1298
lath and plaster	\$ 275
painting inside and out	\$ 971
heating	\$ 575
plumbing	\$ 440
electrical	\$ 546
landscaping allowance	\$ 100
contingency sum	\$ 100
contractor's profit	\$1100

TOTAL COST \$12,450

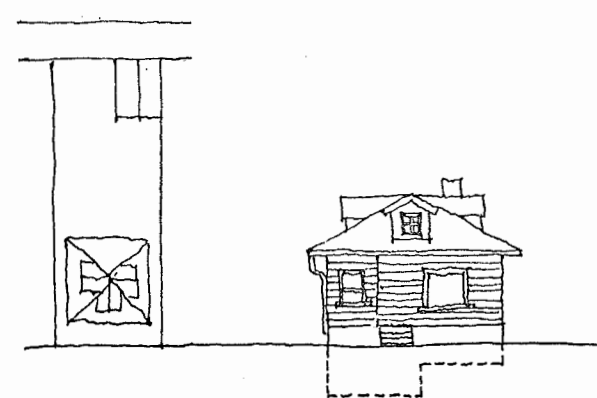

NOTE: Not included in this cost is the time of the architect, specification writer mechanical/electrical/structural consultants and supervision time.

ADD \$2000

TOTAL GROSS COST \$14,450

In examining this project, one sees the tremendous amount of time and money involved in a total renovation job of this sort. If we compare it to the house repaired by "the local handyman", we see how he was able to utilize his time, used materials, and cheap, reliable help in making his job a success. Not only had he saved a house but he made some money for himself.

R. A LOCAL REHABILITATION COMPANY:

Another alternative in making use of the local talent as well as involving the community is to establish a community based rehabilitation company.

This company would be made up of residents with building skills, funded initially by the government, by contract obliged to use local labor and with free access to professionals, if needed. The scope of their work could include partial repair work as well as complete renovation work. The company could be either:

A. after an initial injection of capital by the government, it could be self-supporting, showing a profit. In this way, it could be free of government inspection and carry on its work within this existing fabric of neighbourhood relationships. It could do work without getting a permit, utilize used materials, etc.

B. it could act as a general contractor with the government being the client. The government then would issue a general specification for the jobs and it would be up to the company to select the jobs and carry them through. The company would hire workmen and pay an



hourly wage. Any jobs too large for the company would be sub-contracted. The company would do this work on a cost-plus basis submitting a bill to the government.

C. the government could pay the salaries of the company which would include administrative and labor staff. The company would select projects and within a certain budget provided by the government, work on these jobs. The cost of the job to the owner could then be rationalized through some form of financing.

In any of these proposals there could be room for the occupant of the house to assist in the work thereby reducing his and the government's cost.

#### S. PARTIAL RENOVATION AND REPAIR:

This aspect of rehabilitation has been mentioned earlier as a very important phase of any community rehabilitation program. Why isn't it happening now?

1. high cost home improvement loans
2. fear of rising assessment taxes
3. lack of know-how

The first problem could be solved by introducing special legislation allowing lower interest loans, by government, to people of lower incomes. These loans could be offered to local owners and landlords.

The second problem could be solved by an education program on why assessment taxes go up. If this were carried out, people would know what they could or could not do. Another possibility is a several year moratorium on assessment tax increase for people of lower income in a designated area.

The third problem could be approached through either a local rehabilitation company or a "repair team" of locals and professionals giving advice. As mentioned earlier, this team could not only advise on what had to be done and how, but also survey the need for larger renovation work.

Another problem not easily solved is the one related to "I don't know what is going to happen in the future". Nobody really does, but the government could assure the residents that any money put into a house, if torn down, would be re-paid. The residents could keep the bills and send to the government.



T. HOW CAN ABSENTEE LANDLORDS FIT INTO A PROGRAM?

Many houses in the area are owned by non-resident landlords and these are usually the houses which are in a poor state of repair. It seems the only way, other than developing a meaningful set of standards and a system of enforcement, is to appeal to the selfish-interest of the landlord.

The basic concept of the scheme would be to offer a lump sum of money to non-resident owners having houses in a designated area. This money would be fairly cheap to borrow. There might be conditions attached to the loan related to a minimum/maximum loan and what it is to be used for - it should be used for necessary repairs and not a new paint job. The cost to the landlord of the loan would have to be fairly reflected in a small rental increase. Thus, the inducement to the landlord is that he gets money much cheaper than he can on the private market, makes repairs he would have had to make anyway, charges only his cost to the tenants so it has not cost him anything and now has a better building he can sell at a higher price. To avoid over-burdening the tenant, a loan ceiling must be established. One might say the chance at cheaper money is enough of an inducement, why let the landlord reflect it in his rents. This is a possibility but one wonders about the amount of interest caused by this scheme.

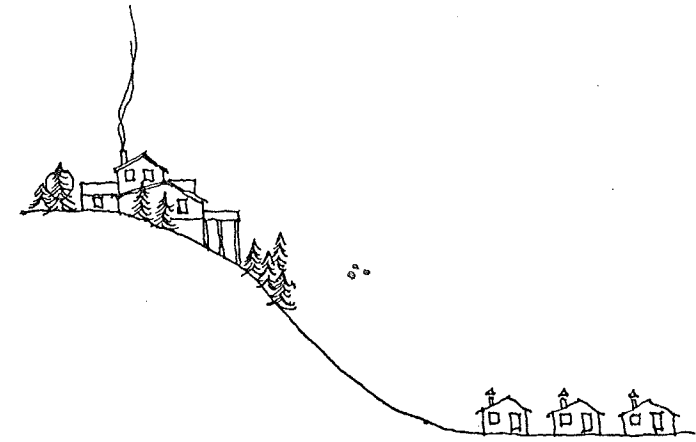

WHAT ARE THE COSTS?

A. Home Improvement Loans

\$1000 at 10% for 5 years	21.15/month
\$1000 at 10% for 10 years	13.11/month

B. Low-Interest Loan to the Landlord

\$1000 at 7% for 25 years	7.01/month
\$1000 at 7% for 35 years	6.32/month
\$3000 at 7% for 25 years	21.03/month
\$5000 at 7% for 25 years	35.05/month

Thus, if we take an average of three households for each house, the rent increase would be divided by three. If the landlord borrowed \$3000, the rent increase would be \$7.00/month. Thus we can see the increase is not too great.

One of the problems with this scheme is the front-end, entrepreneurial cost to the landlord. These are his costs in time and trouble organizing the work. If this could be handled by a local rehabilitation company or community organization, it would be even more desirable to the landlord.

#### U. EXPERIMENTATION WITH NEW CONSTRUCTION TECHNIQUES AND INTERIOR SPACE

##### RE-ORGANIZATION

With the present construction materials and techniques available, the partial or total renovation of a house is a slow, uncertain and expensive process. Walls, floors and ceilings must be torn apart, old components removed, and new structural, mechanical or electrical components installed. There is a tremendous cost in waste materials and labor time.

New materials and techniques must be found that are geared to renovation. The intent of this experiment would be to resolve methods which would minimize the removal of old material, and maximize the efficiency of installation of new material. A team of people - local handymen, engineers, architects, electricians, plumbers, and material representatives could work on some new answers to the following problems:

1. an efficient method of installing new wiring to expand the capacity of the house.
2. heating systems that can be easily installed, and distributed efficiently

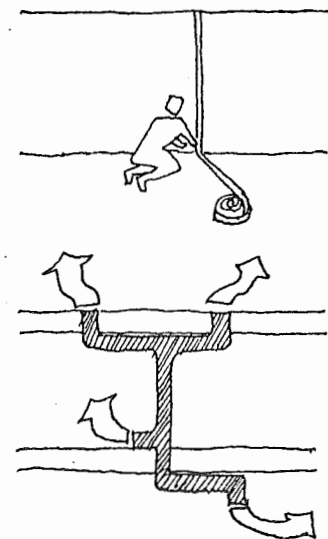

3. an efficient way to run new plumbing in an old building
4. an efficient method of introducing a new bathroom unit
5. ways of covering rotting plaster walls
6. ways to efficiently underpin sagging foundations
7. how to replace rotting joists
8. floor coverings that can be laid over the old
9. ways to effectively insulate an old house
10. methods to eliminate drafts from windows, and new glazing techniques - installing new window openings

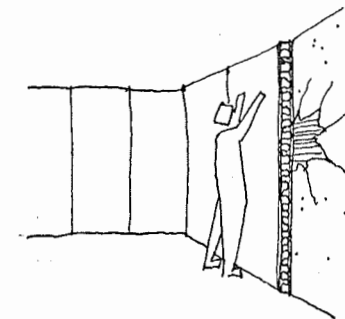
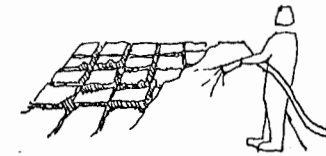
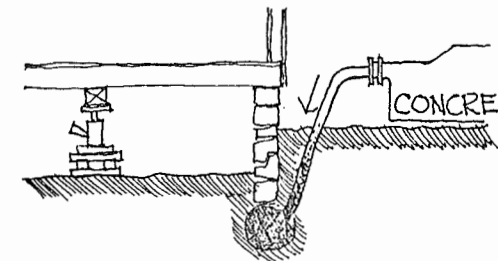
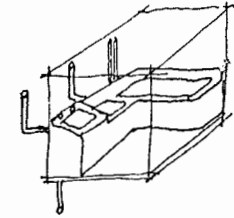
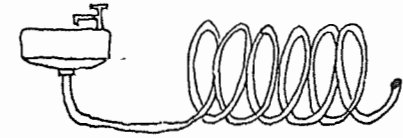

11. ways to lower a ceiling to cut heating bill and give a space a sense of warmth
12. new ways to clad the outside of the house
13. ways of fireproofing

Obviously, some of these materials and techniques exist now and it is just a matter of bringing them to light. But, seldom has any real thought been given to developing new ideas as it was a job usually done by a resident owner in his spare time.

The other part of the experiment would involve the study of possibilities of internal spacial re-organization of an existing house. This would take a look at the following possibilities in context with a few typical examples of real houses now existing in the area.

1. developing self-contained, family or bachelor units with a private entrance, and access to the basement.

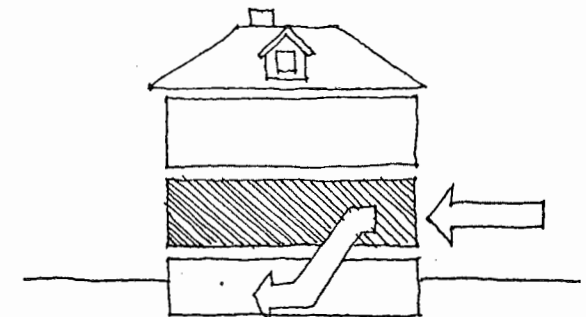
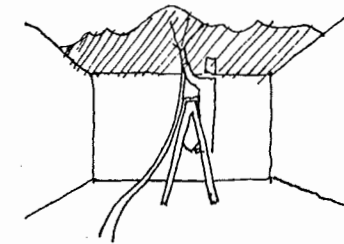
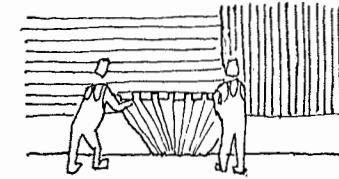
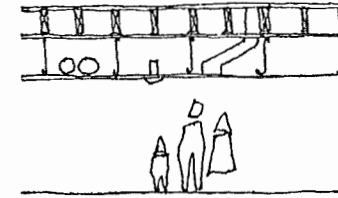

2. maximizing use of space in an older house, using high ceilings to stack beds, living or storage space.
3. look into possibility of removing interior partitions (bearing or not) and creating open space with movable storage units as dividers.
4. turning rear sheds into livable spaces
5. experiment with removal of floors and ceilings to give more space vertically - remove ceiling joists of second floor and build platforms above floor into former attic space.
6. feasibility of adding onto houses with interior space or open decks for second floor suites.

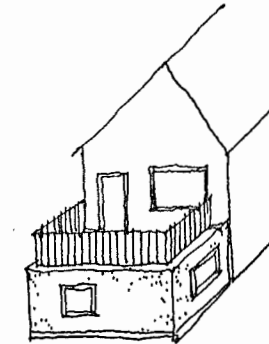
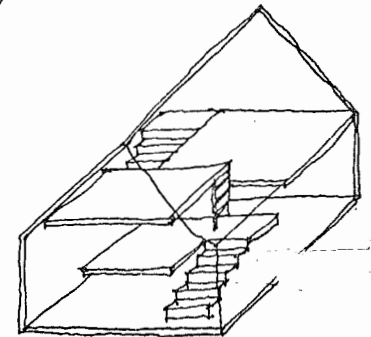
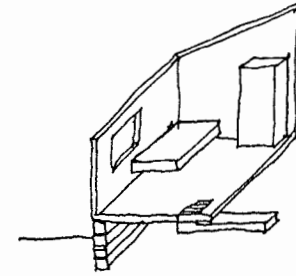
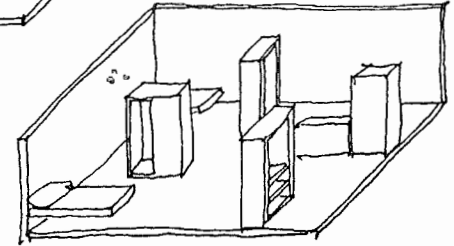
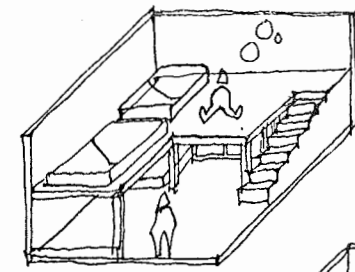

#### V. SUMMARY:

The rationale for a rehabilitation program in an older part of the city is:

1. in considering an established part of the city, one must retain that which is good and eliminate that which is bad. This is not only part of the chemistry of change but also an economic consideration

in that it is cheaper to maintain than to let deteriorate and replace.

2. the houses have been well-built and with repair and maintenance, their life-span can be extended.

3. by spending \$2,500 - \$6,000 on a house, we can provide adequate accomodation which would have not been available or have disappeared and had to have been replaced by a new \$12,000 unit - it is low-cost housing.

4. we must retain and strengthen that which is old, so it can better accept the new.



#### ASPECTS OF A POSSIBLE REHABILITATION PROGRAM

A. establishing a "repair team" of local handymen and professionals to survey neighbourhood need as far as partial repairs or total renovation work is concerned. They would give advice or possibly arrange work to be done. The emphasis here would be advise on minor repair work and testing out cost ceiling principle on first priority repairs.

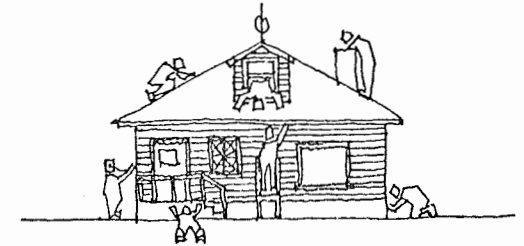

B. establishing a local rehabilitation company to back up the "repair team" and to do the actual renovation or repair work. This company could work as:

- (i) an independent company, initially funded by government
- (ii) a general contractor for the government
- (iii) as salaried employees of the government



C. compile a list of available tradesmen in the area

D. "repair team" could work with construction materials and technical experts on experimenting with new ideas geared to the renovation of old houses.

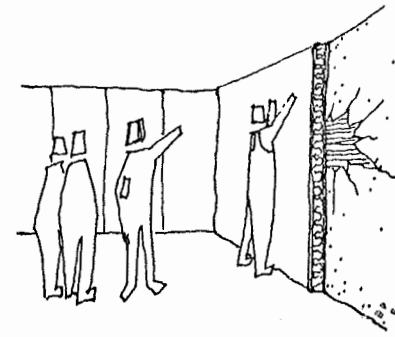

E. do a feasibility study on the possibilities of internal spacial re-organization of an existing house. This would involve a design and cost study.

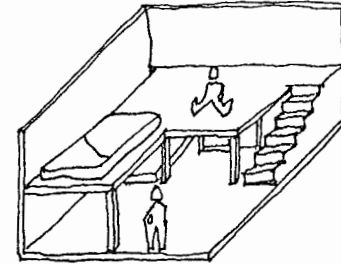

F. study the types of home improvement loans available to these people and look into possibility of lowering cost.

G. study criteria of assessment tax increases and investigate possible moratorium for a few years.

H. study basic health standards, how they are applied and look into a more meaningful set of "adequate" standards. These standards could be geared for lower income people and be more stringent in that they have less buying power and are less able to take advantage of other alternative accomodation.

I. study possibility of a bank of "emergency" accomodation in the form of trailers. These trailers would give the person renting a possible alternative and give the health authorities a chance to enforce their laws without the fear of putting someone in the street.

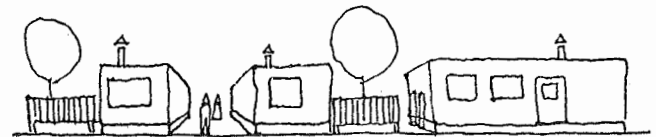

J. study the feasibility of lower cost loans available to absentee landlords to induce repairs on their houses in that most of the poor houses are owned by these people.

K. government could ask for houses to be repaired and offer to buy at a reasonable price or the government could buy poorer houses at the asking price, lower price and offer as "handy-man" specials to the neighbourhood.

L. disseminate information about the "sweat-equity" concept of financing - this information could be part of a larger information service to the community on all matters regarding renovation - taxes, loans, assessment, prices, etc.

M. develop new housing for people in poor houses now to allow them to be torn down or repaired - to act as a safety valve.

